

NOTE: The following instructions provide general guidelines for product installation. For additional information, consult the applicable electrical codes. Contact factory directly for support before attempting anything with uncertainty.

CAUTION: Do not assemble fixture runs on floor.

WARNING: Risk of fire and electrical shock. **DISCONNECT POWER AT ELECTRICAL PANEL** before installing or servicing this product.

GENERAL SAFETY INSTRUCTIONS:

1. Read all instructions prior to installing this fixture.
2. This product must be installed in accordance with the applicable installation code by a person familiar with the construction and operation of the product and the hazards involved.
3. All wiring must be performed by a qualified electrician in accordance with national and local building and electrical codes.
4. This fixture must be suitably grounded for your protection against shock hazards and to assure proper operation.
5. Make sure that the power source conforms to the requirements of this fixture.

Specifications and design subject to change without notice.

PARTS LIST

MAIN PARTS

- A. Luminaire
- B. Wire Entry Canopy
- C. Non-Wire Entry Canopy
- D. Aircraft Cable
- E. Gripper
- F. Lens
- G. Reflector

OTHER PARTS

- Joiner kit (not shown)

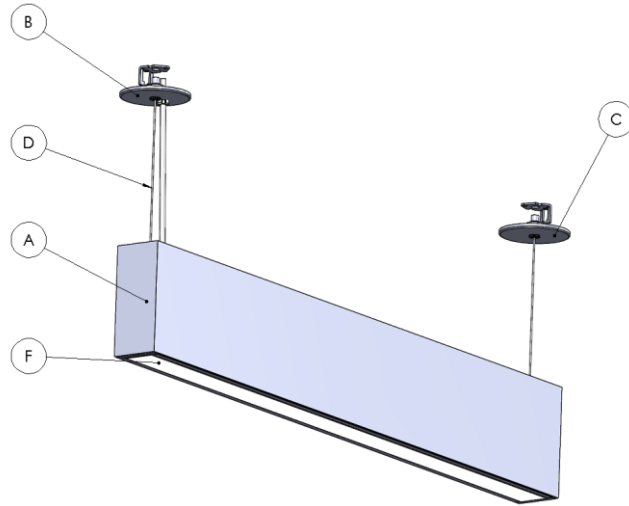

REQUIRED TOOLS

DRILL	#8 PHILLIPS BIT	#8 PHILLIPS SCREWDRIVER	WRENCH	Plastic/latex gloves
				

Important: Use clean gloves to avoid adding oil/dirt to optics surface. Avoid scratching optics by using installation tools with soft plastic rounded edges

Specifications and design subject to change without notice.

WIRING DIAGRAMS

Standard Wire Entry



Battery Wire Entry



Emergency Wire Entry



Specifications and design subject to change without notice.

STEP-BY-STEP INSTRUCTIONS

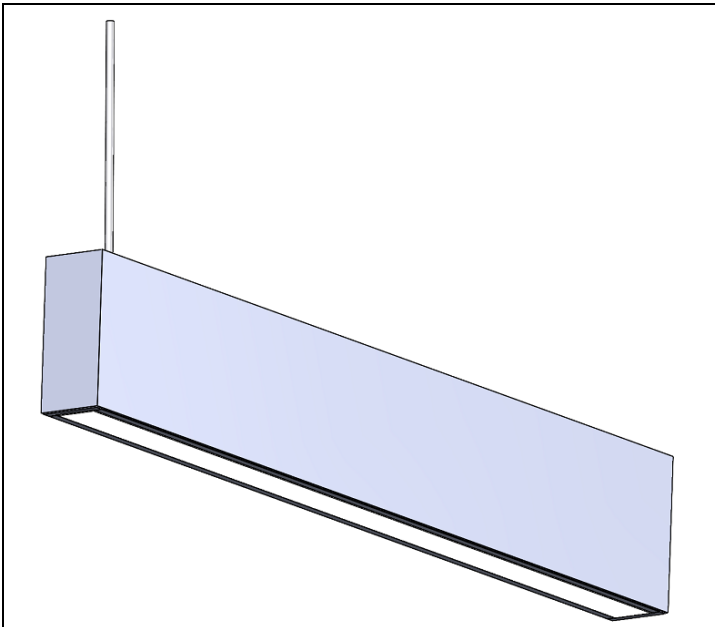

STEP 01. Remove fixture and hanger kit packaging; note power cord(s) coming out at the top of the luminaire.

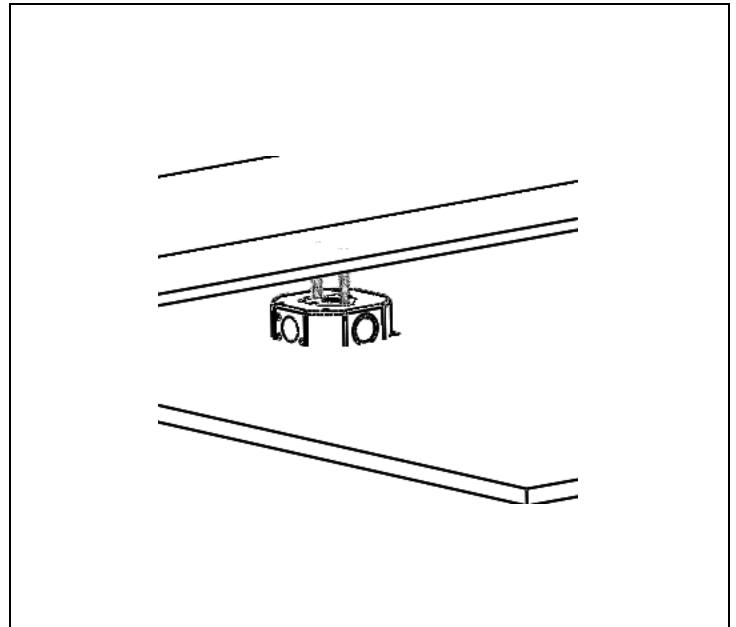

STEP 02. Secure Hex-Box (supplied by others) to a structure of suitable strength to support the fixture.

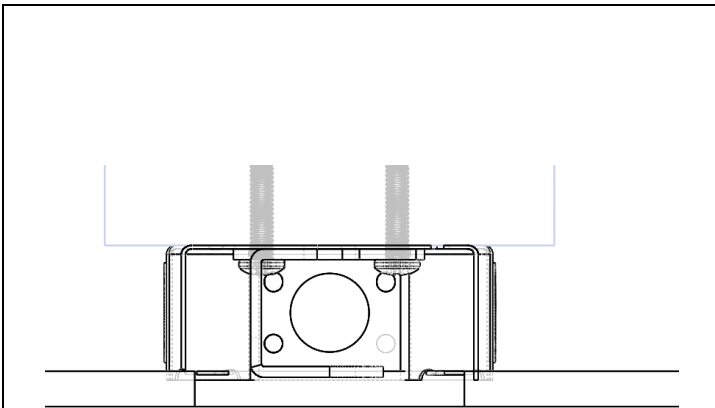

STEP 03. Secure hanger bracket to the hex box.

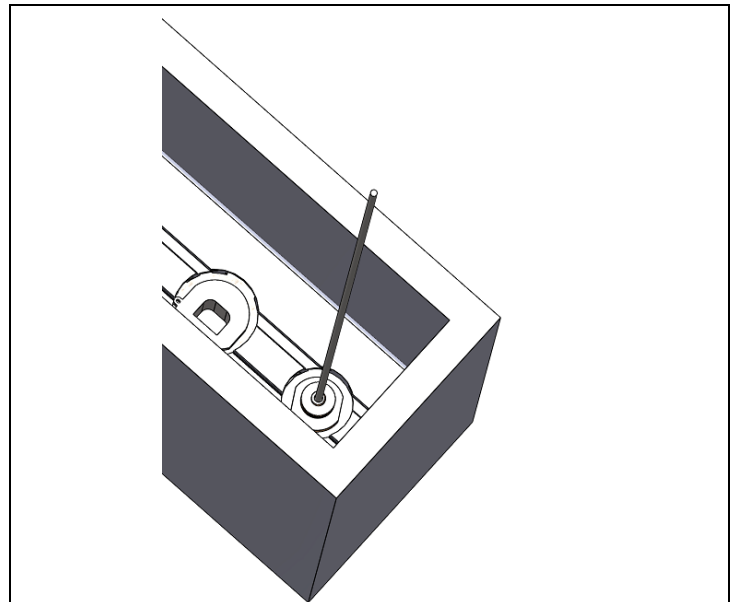

STEP 04. Adjust the length of the hanger by pushing and pulling the cable through the gripper.

Specifications and design subject to change without notice.

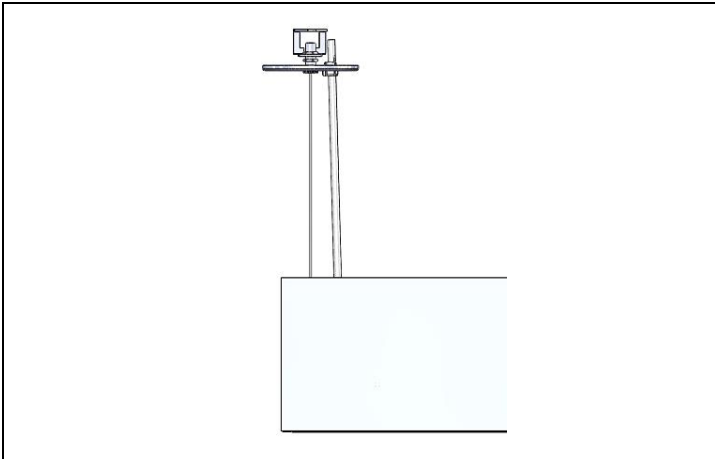

STEP 05. Wire fixture to line voltage as per wiring diagram.

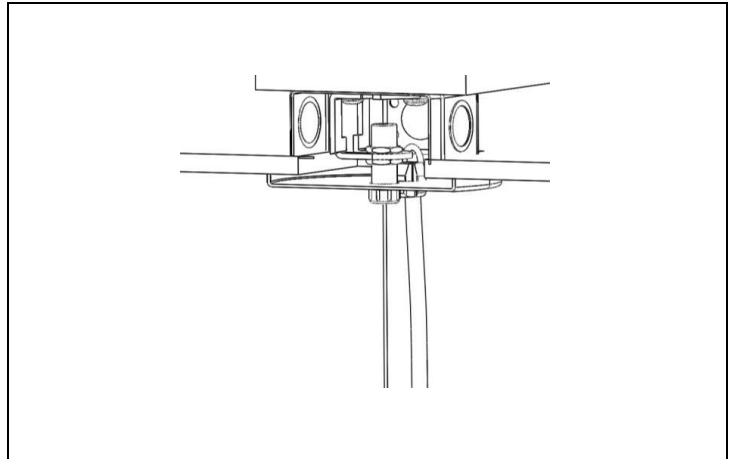

STEP 06. Secure the hanger canopy to the ceiling.

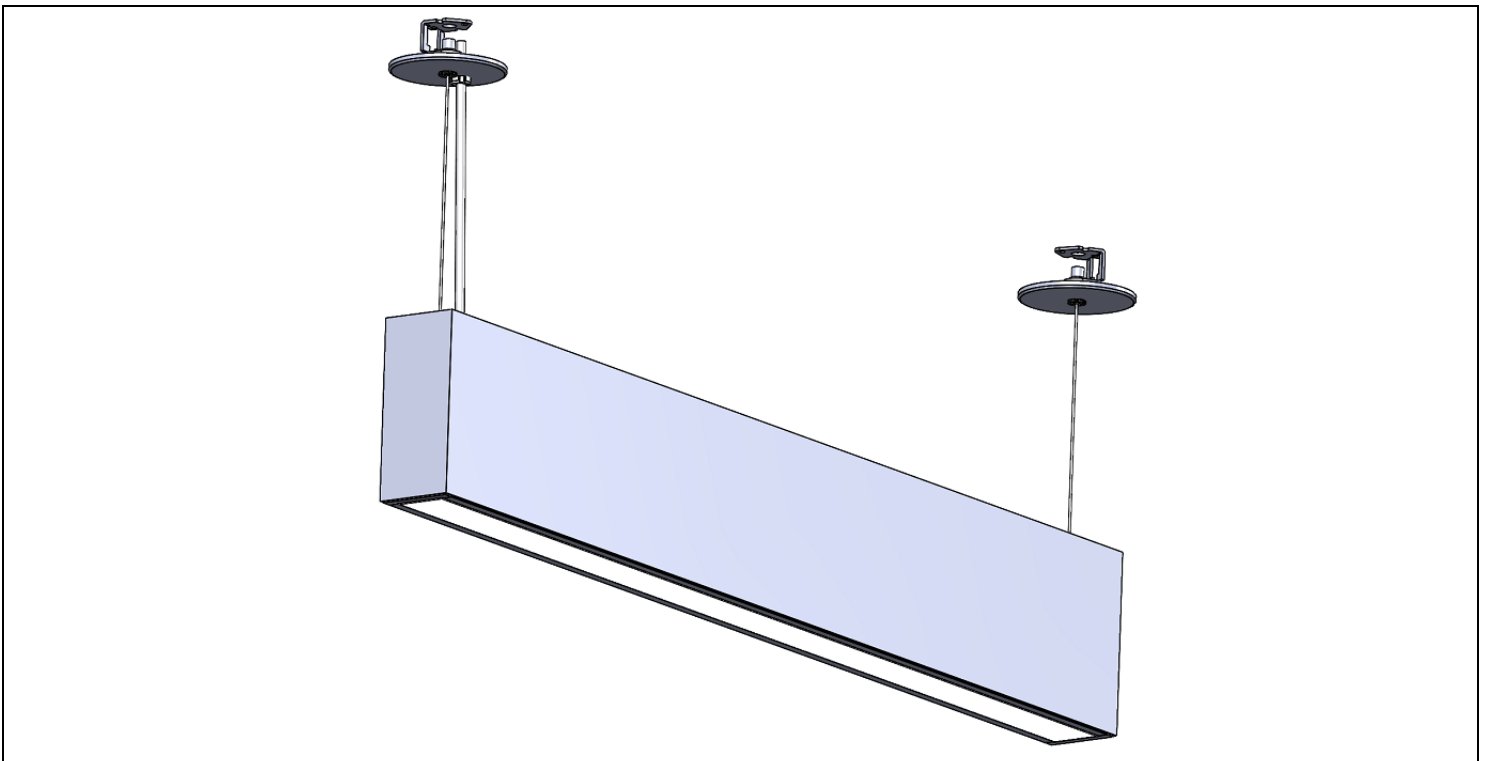

STEP 07. Example of completed fixture.

Specifications and design subject to change without notice.

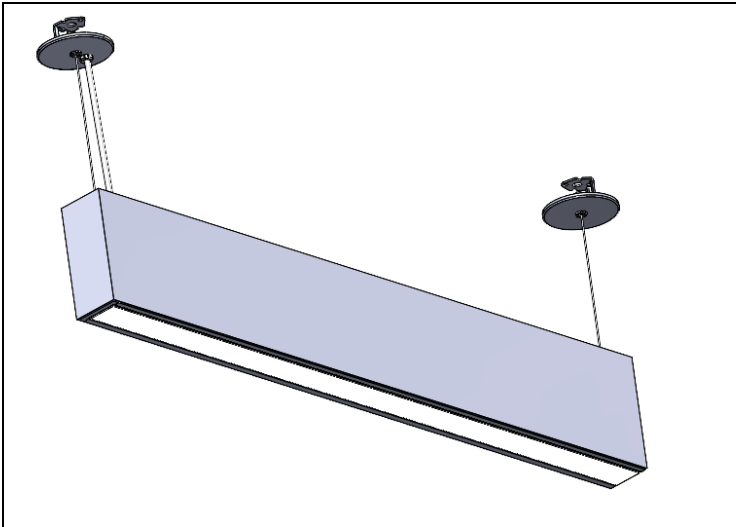

STEP 08. For continuous runs, install Start fixture first as per Steps 1 to 7. Do not apply power.

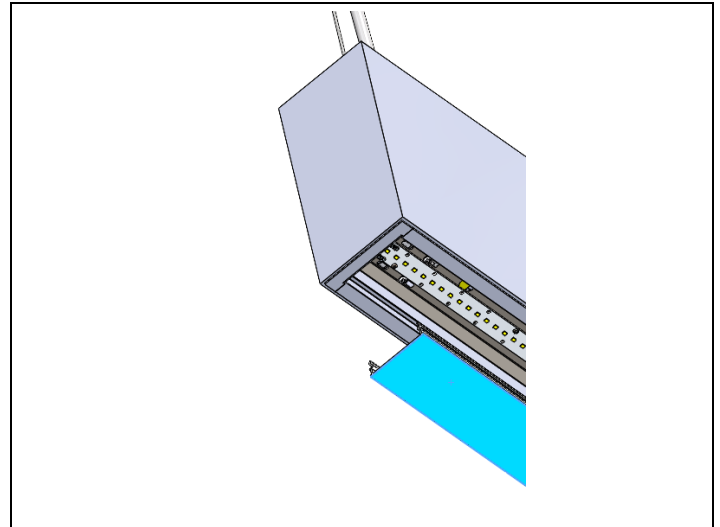

STEP 09. Remove the lens from the mid/end unit.

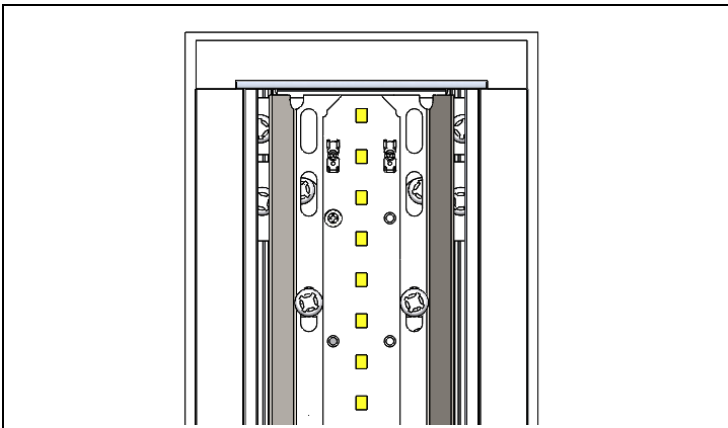

STEP 10. Unscrew the reflector assembly inside the mid/end unit.

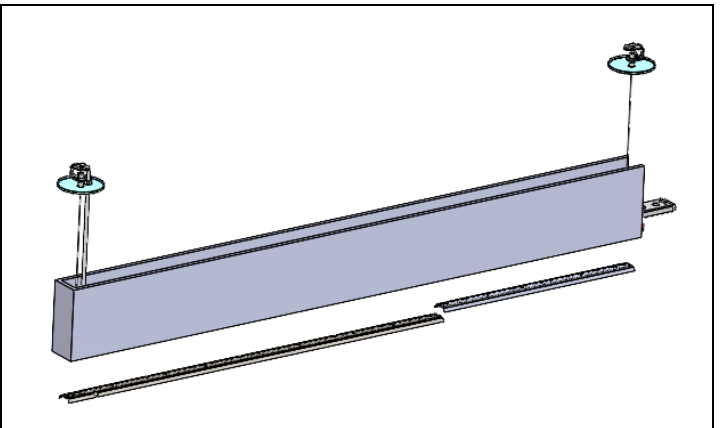

STEP 11. Remove the direct reflector assembly from mid/end unit.

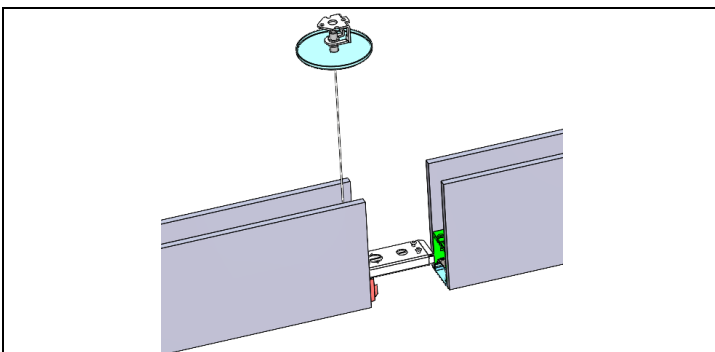

STEP 12. Align mid/end fixture with the start and slide it into place. Secure with screws. Install the hangers. Reinstall reflector assembly and lens in mid/end. Perform necessary wiring between fixtures.

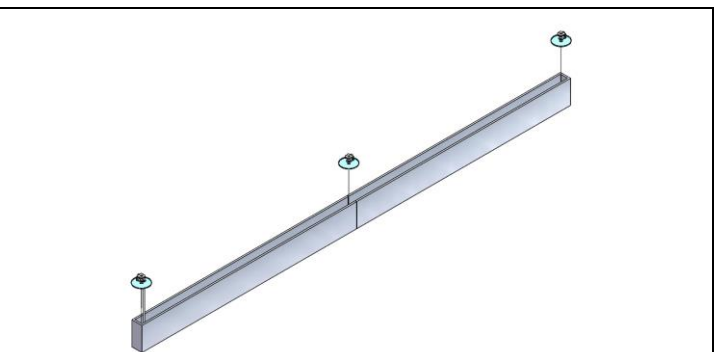

Specifications and design subject to change without notice.

MAINTENANCE

REQUIRED TOOLS:

- Philips screwdriver
- Plastic/latex gloves

Maintenance notes: Use **clean gloves** to avoid adding oil/dirt to reflector surface. Avoid scratching reflector surface by using installation tools with soft plastic rounded edges.

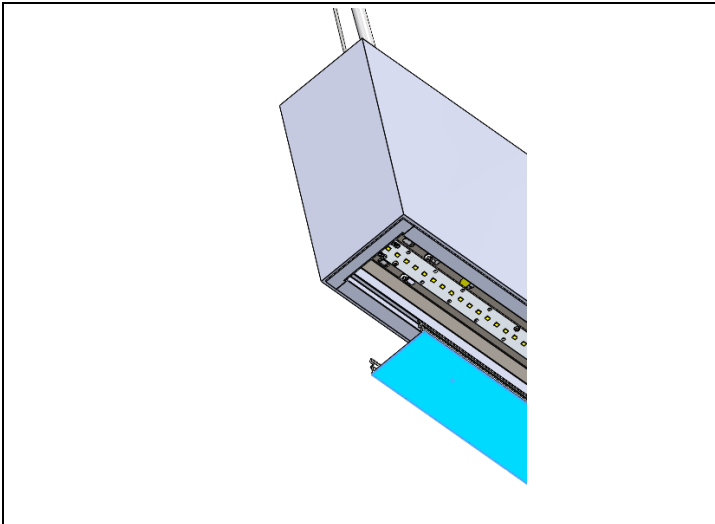

STEP 01. For LED board maintenance, remove the lens from the bottom of the unit.

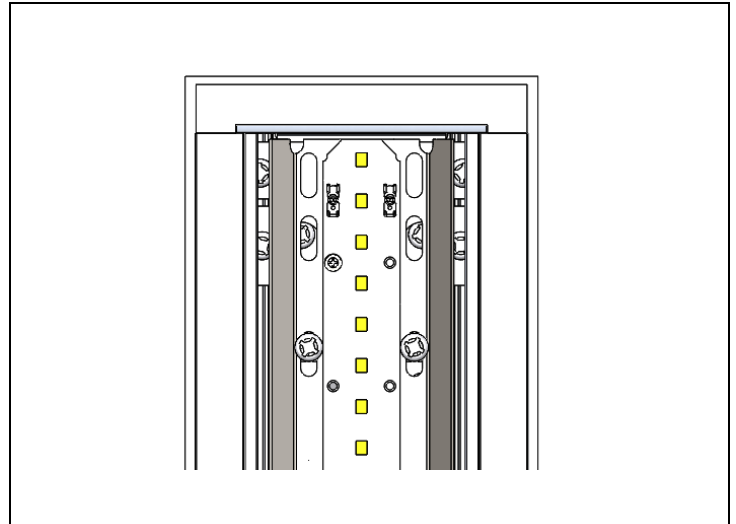

STEP 02. For driver maintenance, first unscrew the reflector assembly.

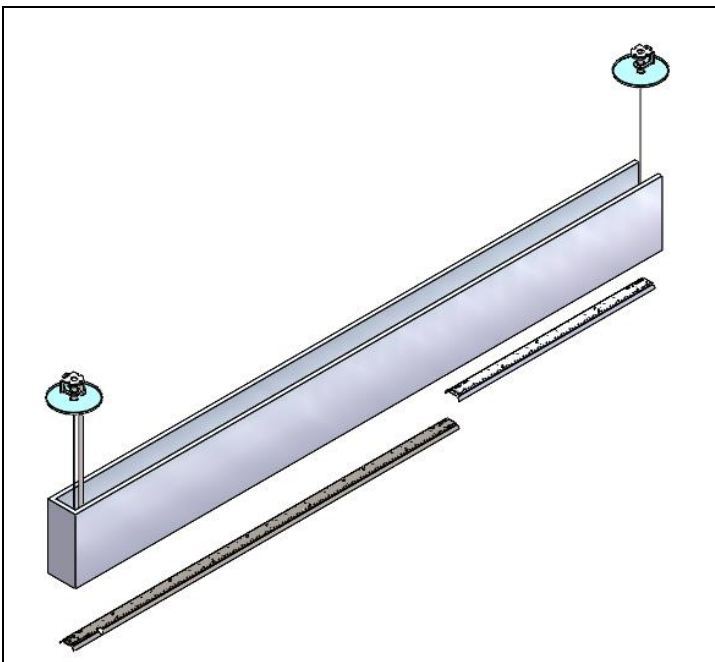

STEP 03. Remove direct reflector assembly from unit.

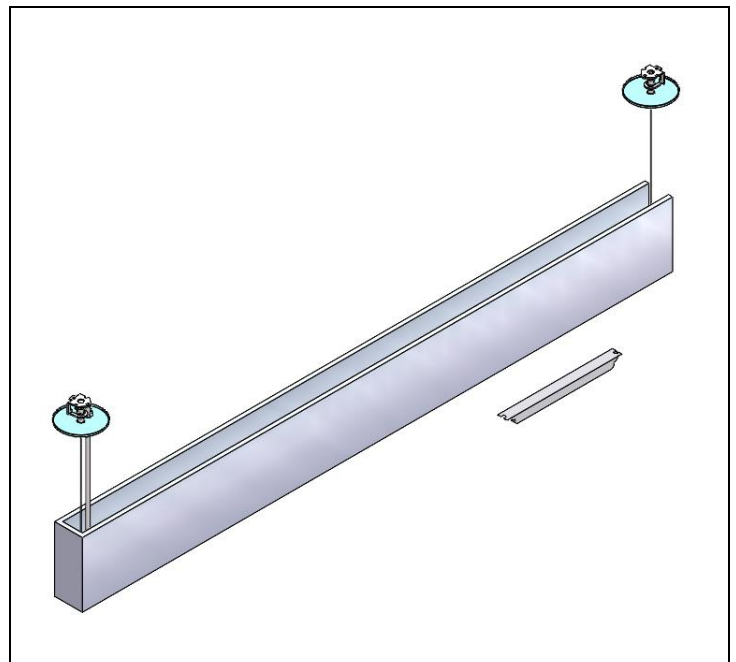

STEP 04. Remove and service driver as required.

Specifications and design subject to change without notice.