

NOTE: The following instructions provide general guidelines for product installation. For additional information consult the applicable electrical codes or contact factory directly for support before attempting anything with uncertainty.

CAUTION: Do not assemble fixture runs on floor.

WARNING: Risk of fire and electrical shock. **DISCONNECT POWER AT ELECTRICAL PANEL** before installing or servicing this product.

GENERAL SAFETY INSTRUCTIONS:

1. Read all instructions prior to installing this fixture.
2. This product must be installed in accordance with the applicable installation code by a person familiar with the construction and operation of the product and the hazards involved.
3. All wiring must be performed by a qualified electrician in accordance with national and local building and electrical codes.
4. This fixture must be suitably grounded for your protection against shock hazards and to assure proper operation.
5. Make sure that the power source conforms to the requirements of this fixture.

Specifications and design subject to change without notice.

PARTS LIST

MAIN PARTS

- A. Luminaire Enclosure
- B. Lens

OTHER PARTS

- Reflector/LED board assembly
- Driver and Driver Enclosure assembly
- Power Cord

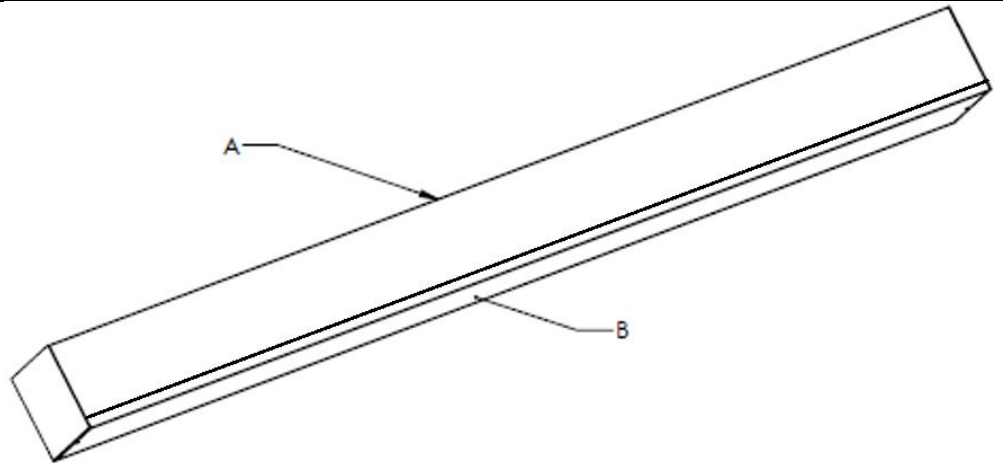

Specifications and design subject to change without notice.

REQUIRED TOOLS

DRILL	#8 PHILLIPS BIT	#8 PHILLIPS SCREWDRIVER	WRENCH
			

Important: Use clean gloves to avoid adding oil/dirt to optics surface. Avoid scratching optics by using installation tools with soft plastic rounded edges

WIRING DIAGRAMS

STANDARD WIRING

(18-6)

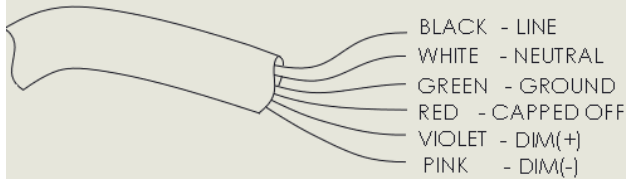

Specifications and design subject to change without notice.

STEP-BY-STEP INSTRUCTIONS

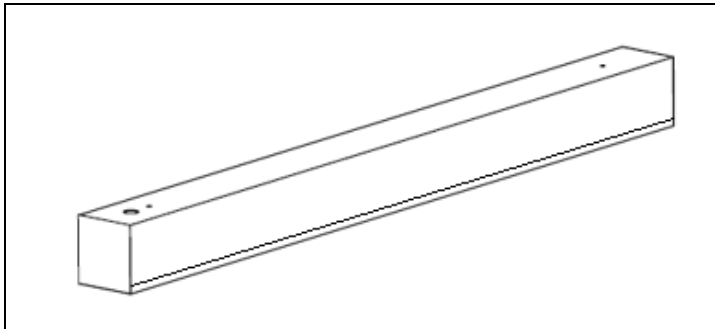

STEP 1. Remove fixture packaging.

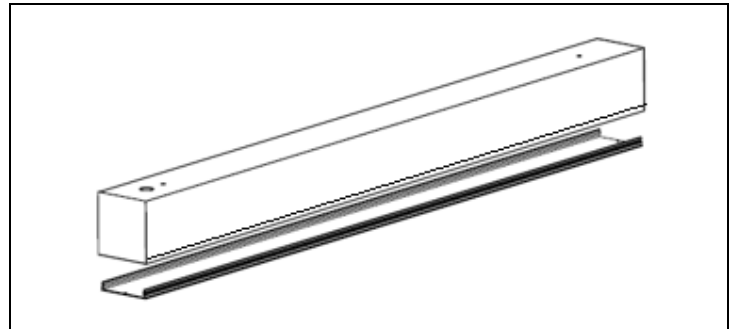

STEP 2. Remove the lens from the fixture.

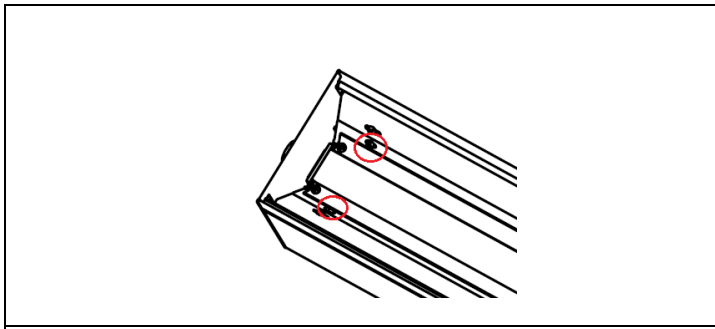

STEP 3. Unscrew the reflector assembly.

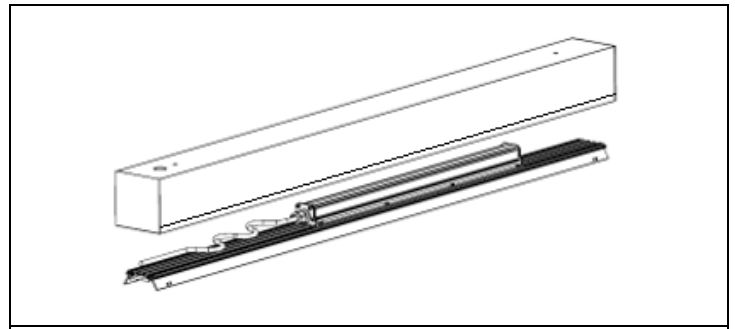

STEP 4. Lower the reflector / driver enclosure assembly

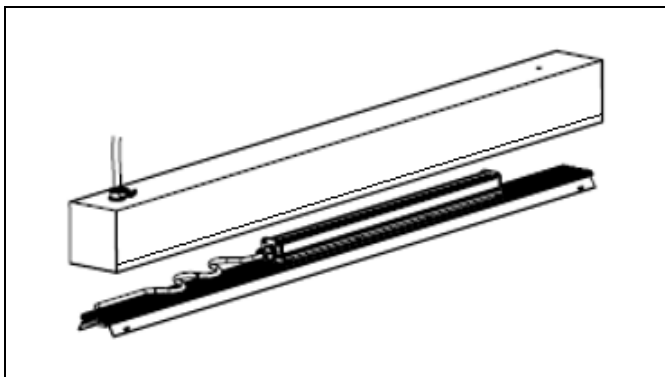

STEP 5. Install BX connector (supplied by others). Feed BX cable (supplied by others) through connector and the body enclosure. Tighten BX connector screw. Wire power cord to BX cable using waterproof wire nuts (supplied by others). Refer to provided wiring diagram.

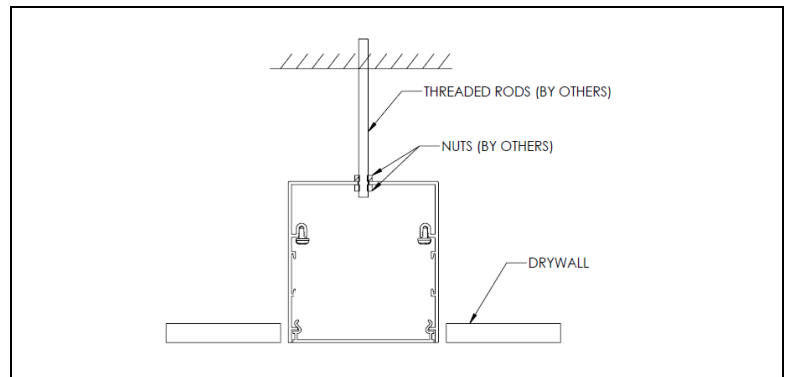

STEP 6. Feed threaded mounting rod (by others) through mounting locations and adjust nut to ensure fixture is parallel to drywall. Insert the fixture all the way through the opening in the ceiling. Insert the second nut (by others) through the fixture and fasten the fixture in place. Repeat with remaining mounting locations until fixture is parallel along entire length. Reinstall reflector / driver enclosure assembly and lens.

Specifications and design subject to change without notice.

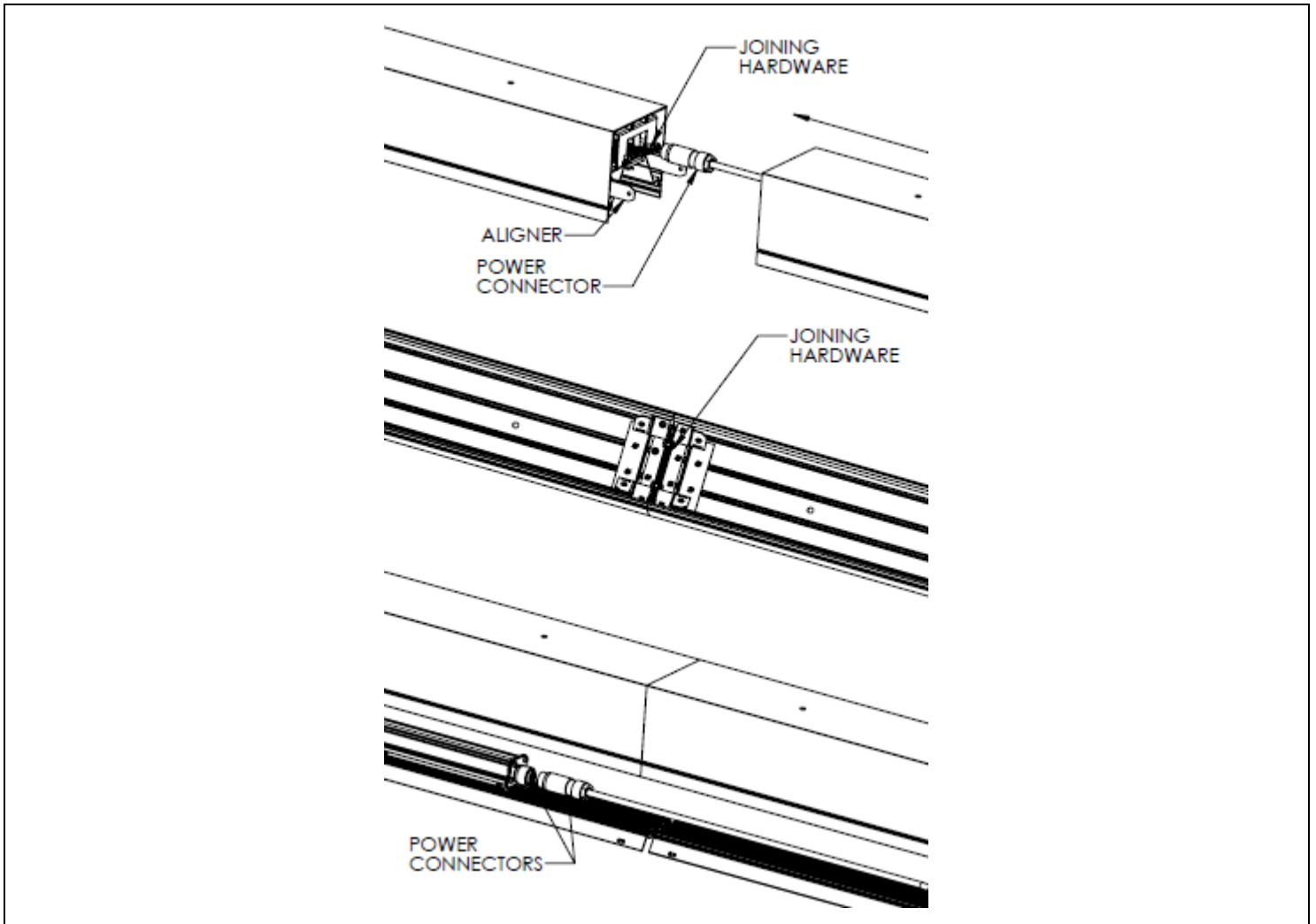

STEP 7. For continuous runs, install Start fixture first (as per steps 1-6). Do not apply power. Install joining fixture (as per steps 1-4 and step 6). Align joining fixture and slide it into place. Secure with joining hardware. And then connect power connectors together. Reinstall reflector / driver enclosure assembly and lens.

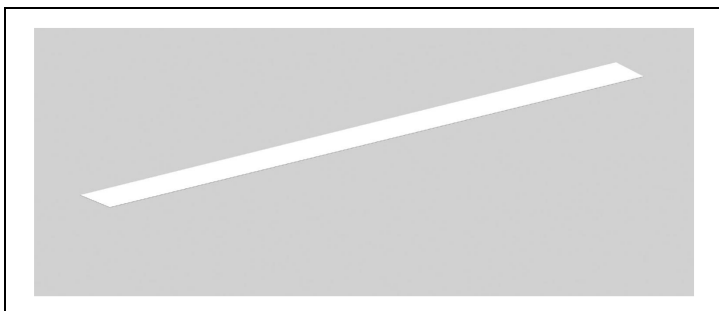

STEP 8. Installed fixture.

Specifications and design subject to change without notice.

MAINTENANCE

REQUIRED TOOLS:

- Plastic / Latex Gloves
- Screwdriver

Important: Use clean gloves to avoid adding oil/dirt to reflector surface. Avoid scratching reflector surface by using installation tools with soft plastic rounded edges.

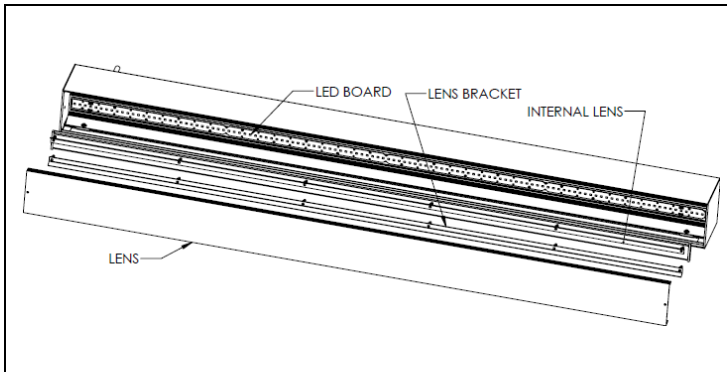

STEP 1. For LED board maintenance, remove lens from the unit. Remove the screws and internal lens holding brackets and then remove the internal lens. Remove the screws for LED board and disconnect wires for LED board. Replace LED board and reinstall the screws and wires back. Reinstall internal lens and lens holding brackets and screws. Snap in the external lens back.

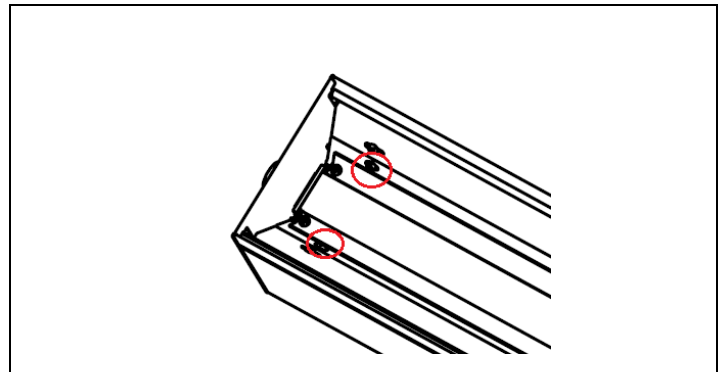

STEP 2. For driver maintenance, remove lens, unscrew the reflector assembly. Lower the reflector / driver enclosure assembly, temporary hung on power cord.

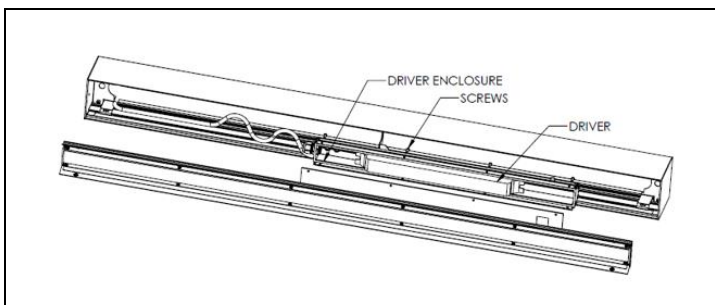

STEP 3. Unscrew driver enclosure screws and separate driver enclosure, cover plate from the reflector.

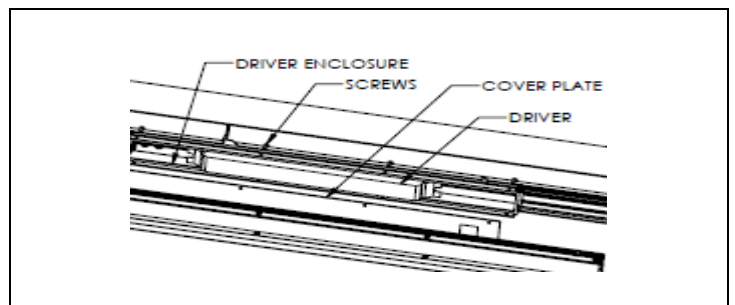

STEP 4. Remove and service driver as required. Be sure to wire correctly (both power and dimming, and the wires to LED board). Reinstall cover plate, driver enclosure to reflector assembly, ensure all wires are inside of the driver enclosure. Reinstall reflector and driver enclosure assembly to fixture. Reinstall lens.

Specifications and design subject to change without notice.